



Three speed pumps | export model\*

# WITA U 80

## Product specials

- Warranty
- Cataphoresis coated pump housing



## Technical Data

Maximum delivery head	7.5 m
Maximum flow	7.750 l/h
Power consumption P1 (W)	84 - 210
Supply voltage	230V 50Hz
Acoustic emission pressure level	< 40 dB(A)
Protective rating	IP 44
Thermal class	TF 110
Operating temperature	0 °C to 40 °C
Fluid temperature	+5 to 110°C
Max. system pressure	10 bar (1 MPa)
Permissible media to be pumped	Water/glycol mixture 1:1
Connection size	DN 25, DN 32
Installation lengths	180 mm
Weight	4.2 kg

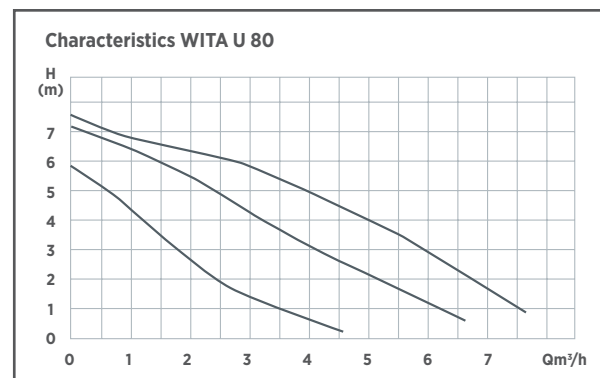
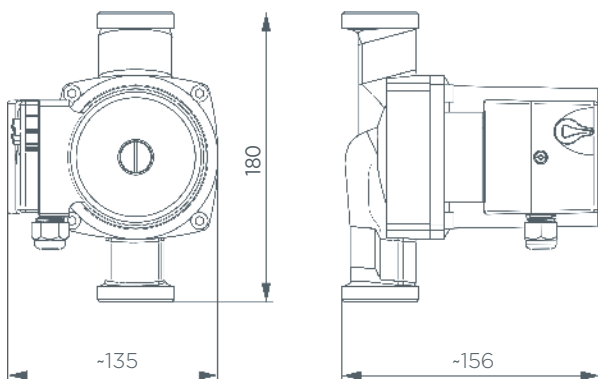

\* available only outside the EU